

SECTION 093000 - EXTERIOR SHEET MEMBRANE WATERPROOFING AND CRACK ISOLATION / JOINT BRIDGING

PART 1 - GENERAL

This specification includes the sheet membrane used as exterior waterproofing and crack isolation / joint bridging in conjunction with tile and dimension stone installations. The content of this section should be combined with the specification for the tile and stone finishes including the setting materials required to complete the sheet membrane installation.

1.1 SUMMARY

Typical Floors and Walls: **Noble Deck™** sheet membrane may be installed for exterior waterproofing and crack isolation on concrete decks, plazas, balconies, walkways, etc., in horizontal or vertical applications. Plywood substrates may also be suitable if they are covered with a reinforced mortar bed or suitable cementitious backer board.

Acceptable Floor Substrates: Concrete and plywood with a reinforced mortar bed or suitable cement backer board.

Acceptable Backer Boards: Cement backer board, in accordance with TCNA Handbook recommendations and manufacturer's installation instructions.

A. Section Includes:

1. Sheet membrane waterproofing for exterior installations.
 - a. Sheet membrane bonded to an assembly including exterior glue plywood (EGP) with reinforced mortar bed or suitable cementitious backer unit (CBU).

The next two paragraphs describe Noble Deck used on floors for waterproofing and/or crack isolation. Select the required installation method.

- b. Sheet membrane bonded to substrate with Latex-Portland Cement Mortar.
- c. Sheet membrane bonded to substrate with adhesive.

1.2 REFERENCES

- A. ANSI A108.13 - Installation of Load Bearing, Bonded, Waterproof Membranes for Thin-Set Ceramic Tile and Dimension Stone.
- B. ANSI A118.10 - American National Standard Specifications for Load Bearing, Bonded, Waterproof Membranes for Thin-Set Ceramic Tile and Dimension Stone Installation.
- C. ANSI A118.12 - American National Standard Specifications for Crack Isolation Membranes for Thin-Set Ceramic Tile and Dimension Stone Installation.

- D. ASTM C627 - Evaluating Ceramic Floor Tile Installation Systems Using the Robinson-Type Floor Tester.
- E. ASTM C920 - Standard Specification for Elastomeric Joint Sealants.
- F. ASTM E96/E96M - Standard Test Methods for Water Vapor Transmission of Materials.
- G. TCNA Handbook - TCNA Handbook for Ceramic, Glass, and Stone Tile Installation.

1.3 ACTION SUBMITTALS

- A. Product Data: For each specified product.
- B. LEED Submittals:

Include the next paragraph for LEED NC, LEED CS, and LEED for Schools.

- 1. Certificates for Credit MR 5: For regional materials, indicating location of manufacturer and point of extraction, harvest, or recovery. Include distance to Project, cost, and fraction by weight for regional components.

Include the next paragraph for LEED CI, only.

- 2. Certificates for Credit MR 5: For regionally manufactured [**and regionally extracted and manufactured**] materials indicating location of manufacturer [**and point of extraction, harvest, or recovery**]. Include distance to project, cost, [**and fraction by weight**] for regional components.

Include the next paragraph for LEED NC, LEED CI, and LEED CS.

- 3. Data for Credit IEQ 4.1: For [**adhesives**] [**and**] [**sealants**], statement of VOC content.

Include the next paragraph for LEED for Schools.

- C. Shop Drawings:
 - 1. Include details sheet membrane waterproofing installation, with flashings and terminations.

1.4 INFORMATIONAL SUBMITTALS

- A. Field quality-control reports.

PART 2 - PRODUCTS

- 2.1 SHEET MEMBRANE EXTERIOR [WATERPROOFING] [AND] [CRACK ISOLATION / JOINT MEMBRANE]

Noble Deck is rated "Extra Heavy" defined by the TCNA Handbook by passing all 14 cycles when tested by ASTM C627 - Standard Test Method for Evaluating Ceramic Floor Tile Installation Systems using the Robinson-Type Floor Tester.

- A. Sheet Membrane: ANSI A118.10, ANSI A118.12; composite sheet membrane made from an alloy of non-plasticized chlorinated polyethylene (CPE) with non-woven fiber laminated to both sides.



1. Basis of Design Manufacturer: Noble Company.
2. Basis of Design Product: Noble Deck.

- B. Performance:

1. System Performance: ASTM C627, Passed cycles 1-14 "Extra Heavy."
2. Moisture Vapor Transmission: ASTM E96, Procedure E, High Temperature: <0.15 perms.
3. Fungus and Microorganism Resistance: Passed per ASTM A118.10.

Include crack isolation for flooring applications. Available ratings are standard performance and high performance based on crack bridging capability.

4. Crack Isolation: Rated "High Performance" in the System Crack Resistance portion of ANSI A118.12.

2.2 ACCESSORIES

- A. Bonding Mortar:

1. Latex-Portland Cement Mortar (Thin Set): ANSI A118.4.

- B. Bonding Adhesive: Type recommended by sheet membrane manufacturer to suit application **[with VOC less than LEED allowable limits]**.

- C. Mortar Bed:

1. Latex-Portland Cement Mortar (Thickset): ANSI A108.02.

- D. Seam Sealant: Waterproof type recommended by sheet membrane manufacturer **[with VOC less than LEED allowable limits]**.

1. Basis of Design Product: NobleSealant 150.

- E. Perimeter Sealant: ASTM C920, construction sealant, type recommended by sheet membrane manufacturer **[with VOC less than LEED allowable limits]**.

PART 3 - EXECUTION

3.1 EXAMINATION

- A. Examine substrates for unacceptable conditions affecting installation of sheet membrane and tile.
- B. Correct unacceptable conditions before installing sheet membrane.

3.2 PREPARATION

Floor slab moisture content may be measured by moisture emission test or by relative humidity test, or both.

- A. Examine, prepare, and test concrete floors for finish flooring installation in accordance with ASTM F710. Perform one **[moisture emission test in accordance with ASTM F1869]** **[relative humidity test in accordance with ASTM F2170]** and one alkalinity test for every 2,000 sf (185 sq. m). Obtain instructions corrective measures from flooring and adhesive manufacturers when test results are not within specified limits.

Use current TCNA guidelines regarding substrate tolerances for large format tile. Verify acceptable limits with tile manufacturer.

- 1. Surface Tolerance: Maximum variation from plane of 3/16 inch (4.5 mm) in 10 feet (3000 mm).
 - a. Floor systems over which tile will be installed shall be in conformance with **[IRC]** **[IBC]** **[applicable building codes]**.

Include moisture emission rate or relative humidity requirements, or both. Coordinate with tests specified above.

- 2. When NobleBond EXT is used as a bonding agent:
 - a. Moisture Emission Rate: Maximum is 4 lbs per 1000 sq ft (1.4 kg 100 sq. m) per 24 hours when tested using calcium chloride moisture test kit for 72 hours.
 - b. Relative Humidity: Maximum 85 percent.
 - c. Alkalinity Range: pH of 7.0 to 9.0.
- B. When tested moisture emission rate exceeds specified maximum, consult membrane manufacturer and bond coat manufacturer for acceptable mitigation methods and materials.

3.3 INSTALLATION OVER PLYWOOD SUBSTRATE

- A. Comply with ANSI A108.13, TCNA Handbook, and the manufacturer's instructions for installation of sheet membrane waterproofing.

B. Exterior applications over wood decks as shown below:

Generally, 3/4 inch EGP is sufficient for ceramic, but deflection requirements for marble are L/720 which may require 2 layers of plywood. A suitable cement backer board or reinforced mortar bed is required before Noble Deck can be installed.

1. General Requirements: Wood deck must be structurally strong to support the deflection requirements of the surface.
2. Apply bonding [mortar] [adhesive] [with backer board] for full coverage of substrate.
3. Install sheet membrane and fully embed into bonding material.
4. Install 19/32 inch minimum, exterior glue plywood on 16 inches on center wood joist spacing.

Exterior Deck - Wood Joist Construction with Backer Board

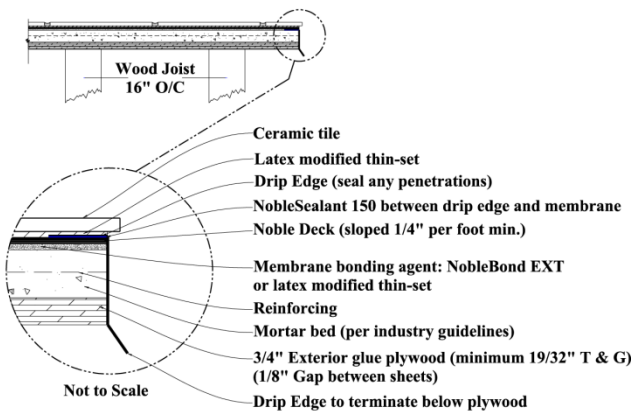

Exterior Deck - Wood Joist Construction with Full Mortar Bed

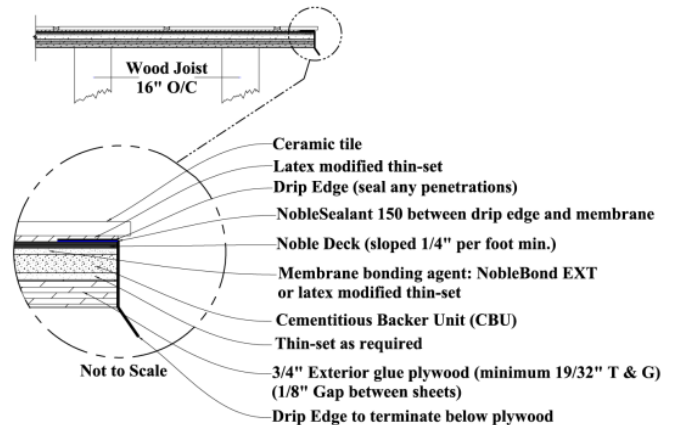

3.4 INSTALLATION - GENERAL

- A. Comply with ANSI A108.13, TCNA Handbook, and the manufacturer’s instructions for installation of sheet membrane waterproofing.

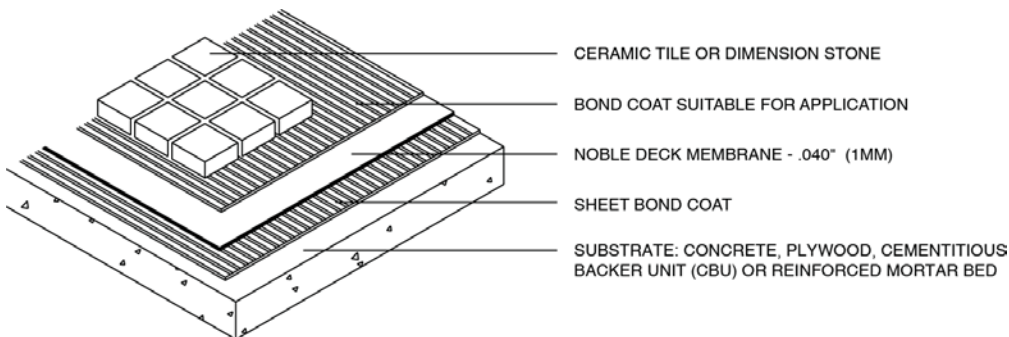

B. Bonded Installation for Thin-Set Applications:

1. Apply bonding [**mortar**] [**adhesive**] for full coverage of substrate.
2. Install sheet membrane and fully embed into bonding material.

C. Embed sheets into bond coat using 75-100 lbs. roller on horizontal areas, working from center of sheets to edges. Use rubber hand roller or flat side of towel with heavy pressure on vertical surfaces.

1. Pull roller edge-to-edge in overlapping passes.
2. Start at end of first sheet installed progressing to area installed last.
3. Remove air pockets using small hand rollers in areas where larger roller will not fit.

Include the next paragraph when membrane will be installed on a floor under a mortar bed.

D. Loose Laid Installation for Mortar Bed Applications:

1. Loose lay sheet membrane on floor substrate that is sloped 1/4 inch per foot to drain.

E. Seal sheet membrane watertight to items penetrating sheet membrane.

F. Upturn sheet membrane above flood plane at perimeters.

3.5 INSTALLATION - SHEET MEMBRANE WATERPROOFING

Include this article when sheet membrane is installed on framing before installation of solid substrates for use at steam room walls and ceilings only.

A. Comply with TCNA Handbook and the manufacturer's instructions for installation of sheet membrane waterproofing.

B. Overlap sheets minimum 2 inches (50 mm) shingle fashion in direction of water drainage. Apply sealant and seal joints watertight.

C. Turn sheet membrane installed on floors up vertical surfaces minimum 1 inch (25 mm) higher than flood plane and bond to substrate.

D. Seal sheet membrane watertight to items penetrating sheet membrane.

3.6 INSTALLATION - SHEET MEMBRANE CRACK ISOLATION

Show locations of sealant (soft) joints on drawings to place the joints in the vicinity of the slab-on-grade control joints.

- A. Comply with ANSI A108.17, TCNA Handbook, and the manufacturer's instructions for installation of sheet membrane waterproofing.
- B. Apply bonding [**mortar**] [**adhesive**] for full coverage of substrate.
- C. Install sheet membrane and fully embed into bonding material.

3.7 FIELD QUALITY CONTROL

Include this article for flood testing floor waterproofing installations, only.

- A. Upon completion of sheet membrane waterproofing installation, plug drains, dam perimeter of waterproofing and fill with water with a minimum depth required by local code and maintain for 24 hours.
 - 1. Inspect waterproofing for leaks.
 - 2. Repair leaks and re-test until watertight.
- B. Prepare test and inspection reports. Indicate corrective measures required to make installation watertight.

3.8 PROTECTION

- A. Protect sheet membrane from pedestrian and vehicular traffic and prolonged exposure to sunlight.

END OF SECTION 093000



P.O. Box 350 · Grand Haven, MI 49417-0350 · 800-878-5788 · Fax: 231-799-8850 · www.noblecompany.com
® Registered Trademark of Noble Company, Grand Haven, MI. ™ Trademark of Noble Company, Grand Haven, MI.