

Pre-Waterproofed ProBase® II

Barrier-Free Ramp

www.noblecompany.com

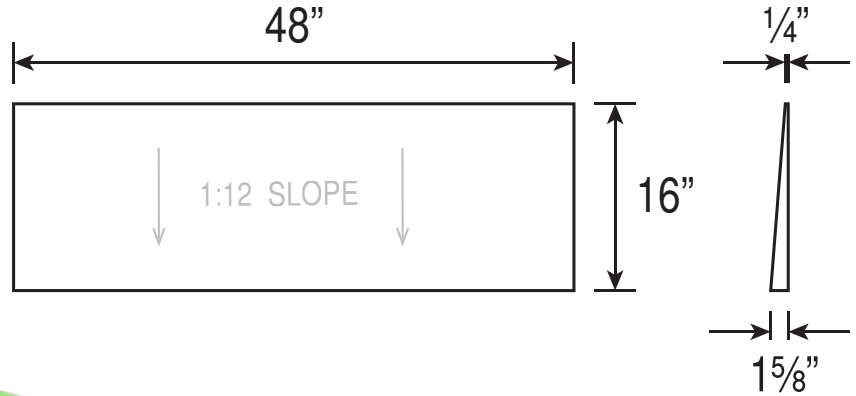

Barrier-Free Ramp

The increase in popularity of barrier-free showers has necessitated the need for accessory products to accommodate this type of installation. The barrier-free ramp provides for a smooth transition to a ProBase II shower base. Compression concerns of the ramp are minimized with the added benefit of Noble Company's patent pending ProBase II composite base construction.

Features:

- Complement to ProBase II Shower Bases
- Ideal for barrier-free installations
- Honeycomb construction for added durability
- Pre-waterproofed for ease of transition to base
- Easy to trim to match shower base height as well as desired width

Part No.	Description
----------	-------------

5148	Barrier-Free Ramp - 48"
------	-------------------------

Made from Patent Pending Foam/Honeycomb Composite for additional compressive strength.

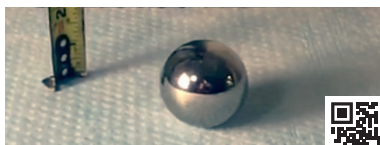
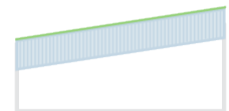

Industry-leading Impact Resistance
Ball Drop Video - Scan QR Code



VIEW MORE PRODUCT
DETAILS, VIDEOS,
AND DIAGRAMS ONLINE



Simple Solutions... Proven Performance



7300 Enterprise Drive, Spring Lake, MI 49456
(800) 878-5788 · Fax: (231) 799-8850 · www.noblecompany.com
® Registered Trademark of Noble Company © 2021 Noble Company

File #PB022021-14 | 02/21

